



E-Box 48100R Specifications

Electrical

Nominal Voltage	51.2V
Voltage Range	47.5V~57.6V
Nominal Capacity	100Ah
Nominal Energy	5.12kWh
Usable Energy	4.608kWh
Recommended Charge/Discharge Current	50A (2.56kW DC)
Maximum Charge/Discharge Current	50A (2.56kW DC)
Peak Discharge Current	102A (5.22kW@15s)

General

Chemistry	LFP
Communication Protocol	CAN/RS485
Dimensions (L x W x H)	440*620*117mm/17.32*24.41*4.61 inch(2.6U)
Weight	51kg / 112.5lbs
Charging Temperature	0°C~ 45°C/32°F~113°F
Discharging Temperature	-10°C~ 50°C/14°F~122°F
Round-Trip Efficiency	≥ 95%
Cycle Life	≥ 6000 cycles
Warranty	10 Years
Scalability	16 pcs (81.92kWh) in a group 6 groups (491.52kWh) in a system w/a Hub

Certifications

UL9540 Ed.2 (2020), UL9540A, UL1973, CEC, SGIP, CE, IEC62619, UN38.3

Compatibility List of PYTES ESS and Inverters



Battery Connection Diagram Guide

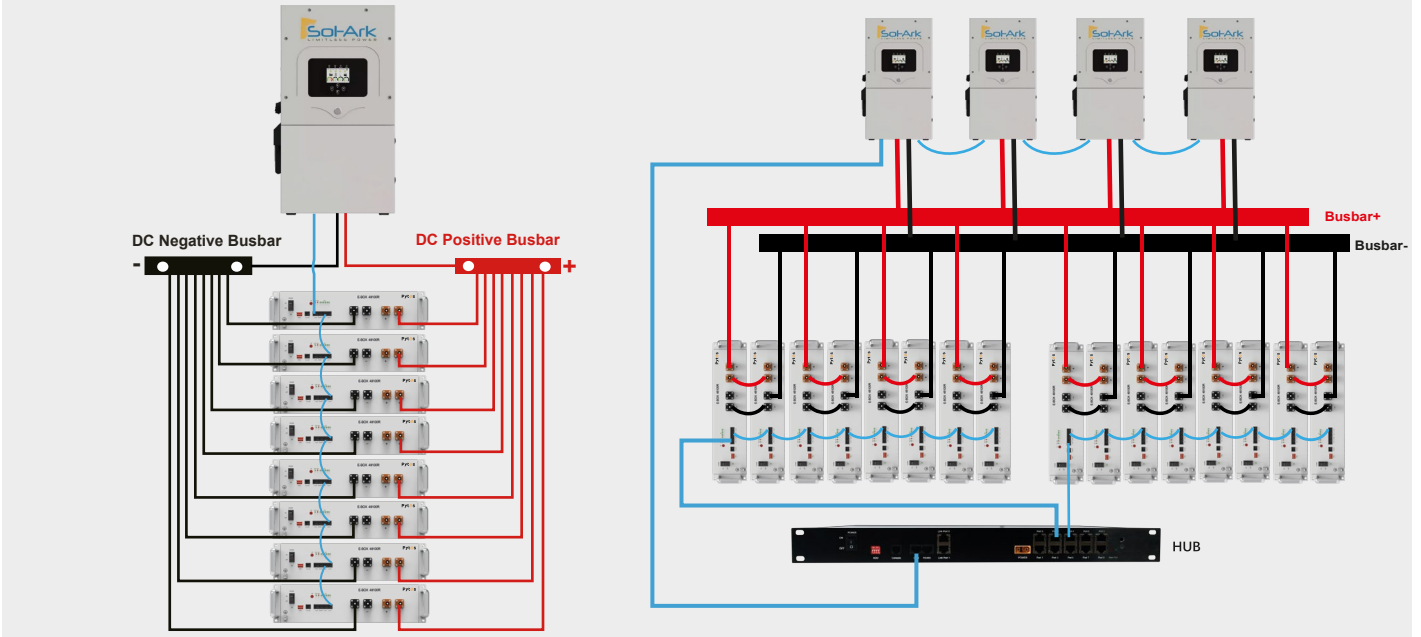

E-Box 48100R Enclosure



48100R Bracket
hold up 1*E-BOX 48100R

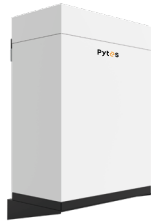

R-BOX
hold up 2*E-BOX 48100R



R-BOX-NEMA3
hold up 2*E-BOX 48100R



R-BOX-OC
hold up 4*E-BOX 48100R



Forest RB Plus
hold up 6*E-BOX 48100R

Case Study



E-BOX48100R

- LifePO4
- 100Ah / 5.12kWh
- Dis/Charge 50A
- 6000 Cycles
- 10 Year Warranty

- DSS SGS NA
- IEC 62919
- MSDS 2022
- UL1973 Test Report
- UL1973-Cert
- UL954A
- UN38.3



Shanghai PYTES Energy Co., Ltd.

Address:NO.3492, Jinqian Road, Fengxian District, Shanghai, China
Email: pytesess@pytesgroup.com
Site: www.pytesess.com



More Catalogs



LinkedIn



Facebook



Instagram



YouTube



www.pytesess.com
Pytes